

ITEM №	PART NUMBER	DESCRIPTION	QTY.
1	CT.3043.017	Creel	4
2	CT.0651.002	Roving dryer	2
3	CT.3076.016	Impregnation module	2
4	CT.0419.008	Weaving module	1
5	CT.0651.016	Curing oven	3
6	CT.0621.007	Cooling module	1
7	CT.3034.009	Pulling device	1
8	CT.3041.050	Roll winder	1
9	CT.3041.048	Automatic coiler	1
10	CT.3041.052	Uncoiler	1

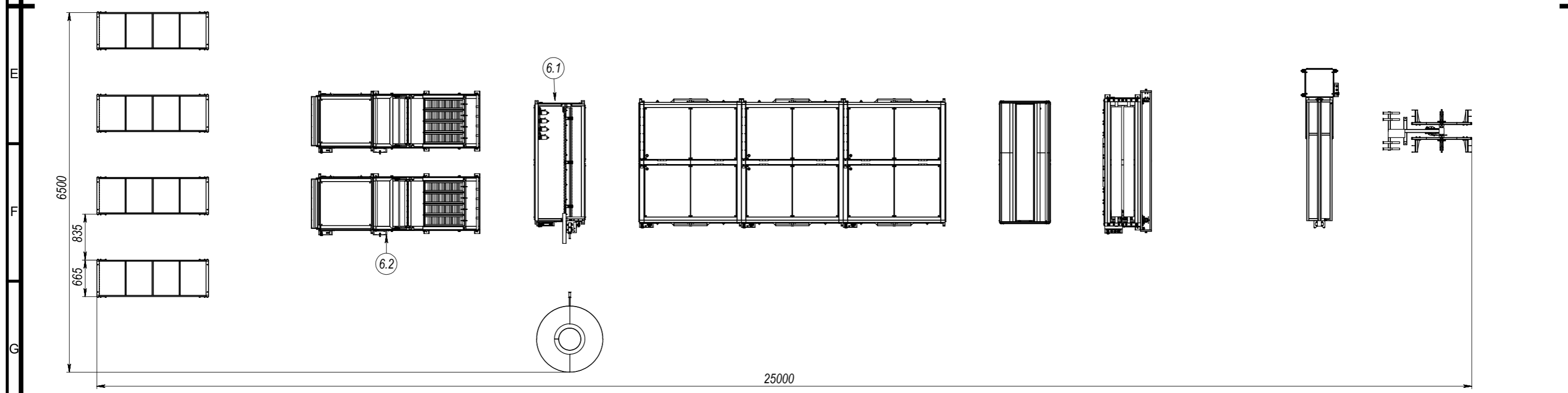
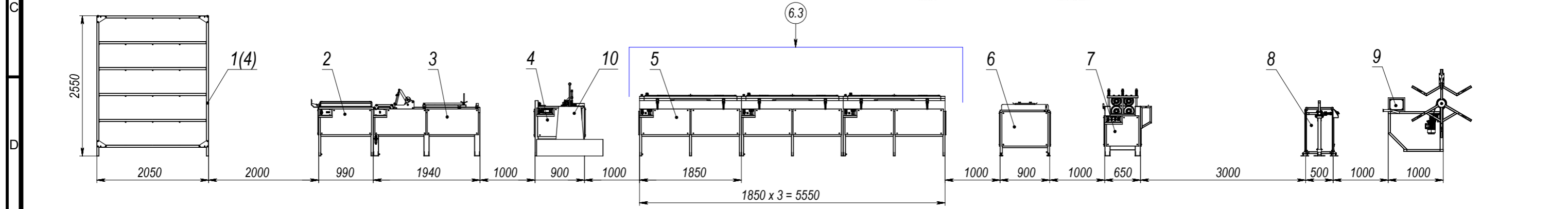

1. Assemble the production line on a flat concreted platform. Line alignment error in any plane no more than 5 mm.
2. Fix the parts of production line by anchor M12x200.
3. Ground the parts of production line.
4. Installation of electrical cables must comply with the electrical circuit diagram.
5. Lay electrical cables in the cable channel.

6. To ensure the operation of production line, energy carriers with the following characteristics are required:
  - 6.1 Three-phase grid 380 V ± 10% with a frequency of 50 ± 1 Hz, - input power 40 kW.
  - 6.2 Compressed air line with a pressure of 0.6 - 0.8 MPa.
  - 6.3 Exhaust ventilation providing at least 20 air exchange rates. Install the ventilation system above the stoves (not included in the delivery set).

This drawing and any information or descriptive material set out on it are the confidential and copyright property of **Composite Tech** and MUST NOT BE DISCLOSED, COPIED, LOANED in whole or part or used for any purpose without the written permission of **Composite Tech**.

Drawn by: <b>Cujba</b>	Date: 10/12 2023	Description: <b>FRP MESH production line CT M2-6</b>
Checked/Approved by: <b>Tifoi</b>	Date: 10/12 2023	Drawing Number: <b>CT.0419.006</b>
Approx Weight:	Revision: <b>A</b>	Document Type: <b>Installation drawing</b>
Sheet Size: <b>A2</b>	Scale: <b>1:50</b>	Sheet: <b>1 of 1</b>
		Unless Otherwise Stated: Linear Tol.: ±0.2 Angular Tol.: 0°15' Surface Finish: Ra12.5 All Dimensions: mm

**COMPOSITE TECH**  
Email: info@composite-tech.com  
FIRST ANGLE PROJECTION